

SPECIFICATIONS

1. MAJOR COMPONENT

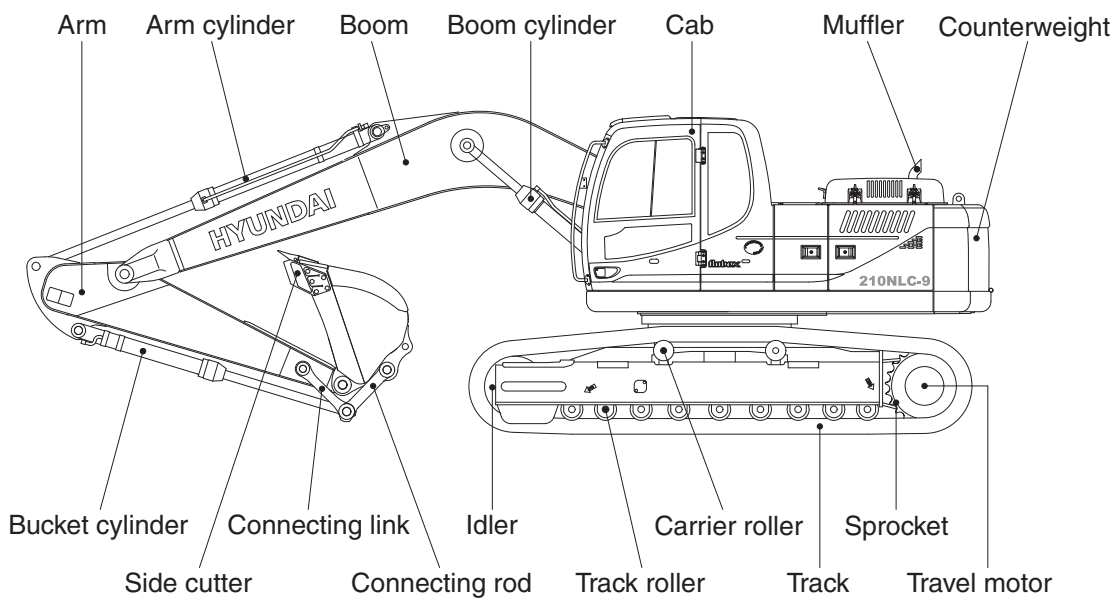
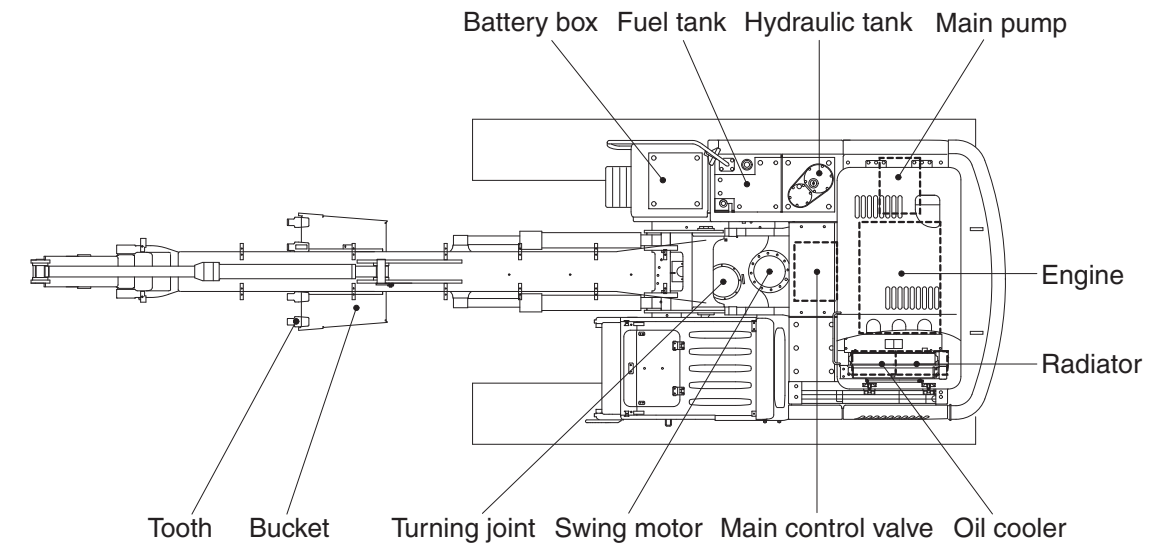

210N92SP01

2. SPECIFICATIONS

1) R210NLC-9

- 5.65 m (18' 6") BOOM and 2.92 m (9' 7") ARM

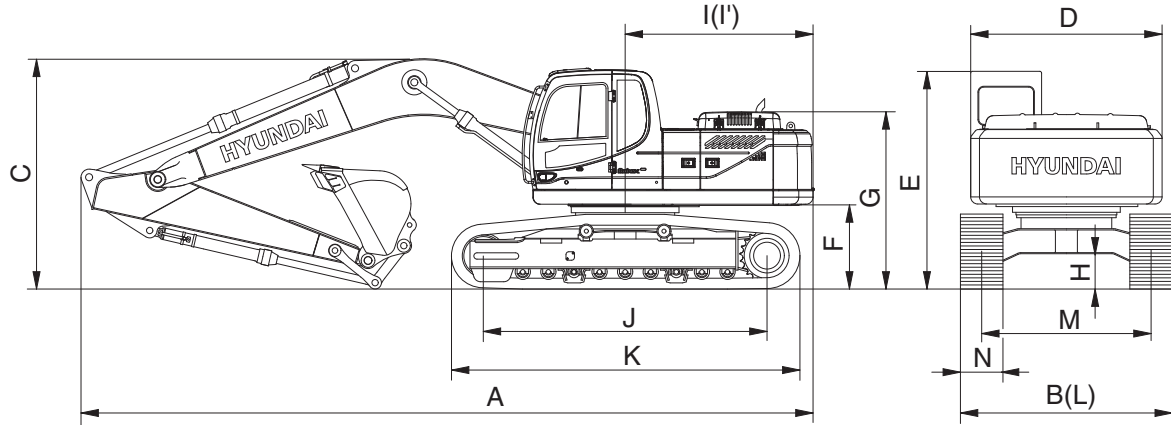

210N92SP02

Description		Unit	Specification
Operating weight		kg (lb)	22000 (48500)
Bucket capacity (SAE heaped), standard		m ³ (yd ³)	0.87 (1.14)
Overall length	A	mm (ft-in)	9510 (31' 2")
Overall width, with 500 mm shoe	B		2500 (8' 2")
Overall height	C		3100 (10' 2")
Superstructure width	D		2530 (8' 4")
Overall height of cab	E		2920 (9' 7")
Ground clearance of counterweight	F		1060 (3' 6")
Engine cover height	G		2320 (7' 7")
Minimum ground clearance	H		480 (1' 7")
Rear-end distance	I		2770 (9' 1")
Rear-end swing radius	I'		2790 (9' 2")
Distance between tumblers	J		3650 (12' 0")
Undercarriage length	K		4440 (14' 7")
Undercarriage width	L		2500 (8' 2")
Track gauge	M		2000 (6' 7")
Track shoe width, standard	N		500 (20")
Travel speed (low/high)			km/hr (mph)
Swing speed		rpm	12.0
Gradeability		Degree (%)	35 (70)
Ground pressure (500 mm shoe)		kgf/cm ² (psi)	0.56 (7.96)
Max traction force		kg (lb)	21100 (46500)

3. WORKING RANGE

• 5.65 m (18' 6") MONO BOOM

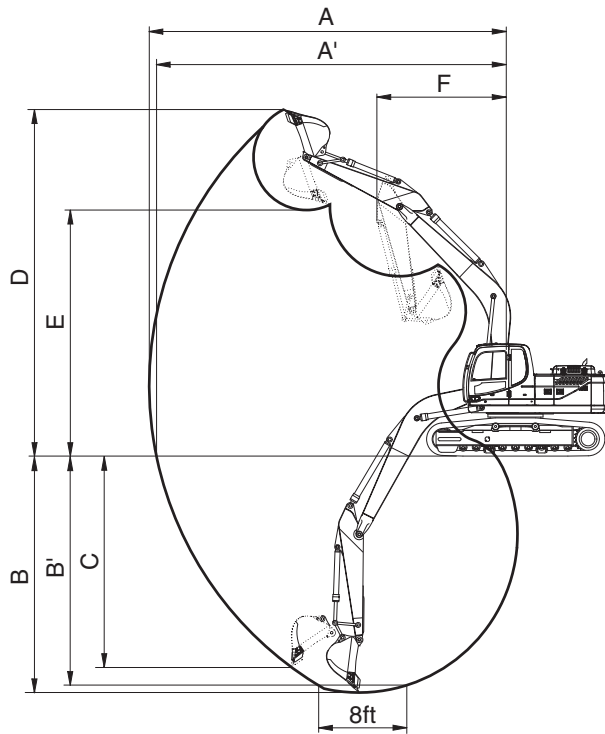

21092SP03

Description		2.0 m (6' 7") Arm	2.40 m (7' 10") Arm	2.92 m (9' 7") Arm
Max digging reach	A	9120 mm (29' 11")	9530 mm (31' 3")	9960 mm (32' 8")
Max digging reach on ground	A'	8940 mm (29' 4")	9360 mm (30' 9")	9800 mm (32' 2")
Max digging depth	B	5480 mm (18' 0")	5890 mm (19' 4")	6640 mm (21' 9")
Max digging depth (8ft level)	B'	5360 mm (17' 7")	5770 mm (18' 11")	6470 mm (21' 3")
Max vertical wall digging depth	C	4560 mm (15' 0")	4990 mm (16' 4")	6250 mm (20' 6")
Max digging height	D	10300 mm (33' 10")	10670 mm (35' 0")	9740 mm (31' 11")
Max dumping height	E	7390 mm (24' 3")	7740 mm (25' 5")	6900 mm (22' 8")
Min swing radius	F	2870 mm (9' 5")	2670 mm (8' 9")	3580 mm (11' 9")
Bucket digging force	SAE	133.4 [147.8] kN	133.4 [147.8] kN	133.4 [147.8] kN
		13600 [14770] kgf	13600 [14770] kgf	13600 [14770] kgf
		29980 [32500] lbf	29980 [32500] lbf	29980 [32500] lbf
	ISO	152.0 [165.0] kN	152.0 [165.0] kN	152.0 [165.0] kN
		15500 [16830] kgf	15500 [16830] kgf	15500 [16830] kgf
		34170 [37100] lbf	34170 [37100] lbf	34170 [37100] lbf
Arm digging force	SAE	144.2 [156.5] kN	119.6 [129.9] kN	102.0 [110.7] kN
		14700 [15960] kgf	12200 [13250] kgf	10400 [11290] kgf
		32410 [35190] lbf	26900 [29210] lbf	22930 [24900] lbf
	ISO	151.0 [164.0] kN	125.5 [136.3] kN	106.9 [116.1] kN
		15400 [16720] kgf	12800 [13900] kgf	10900 [11830] kgf
		33950 [36860] lbf	28220 [30640] lbf	24030 [26090] lbf

[] : Power boost

2) 5.65 m (18' 6") HYDRAULIC ADJUSTABLE BOOM

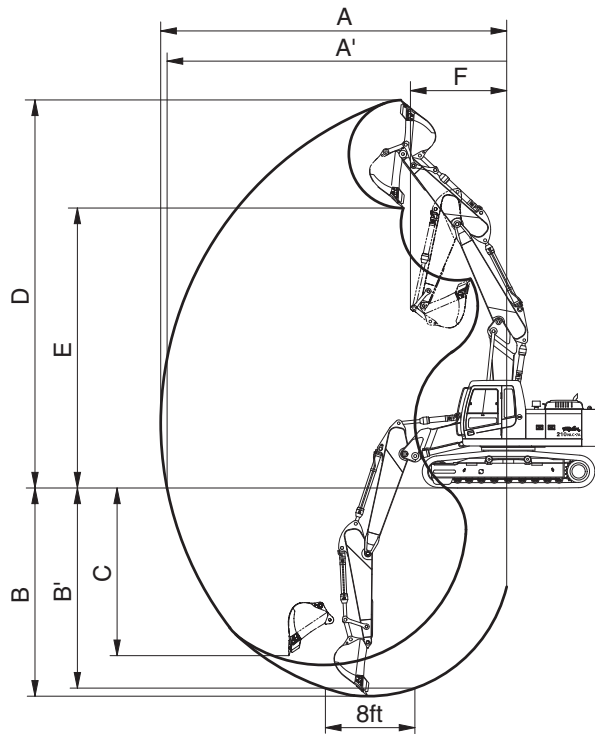

210N7A2SP05

Description		2.0 m (6' 7") Arm	*2.40 m (7' 10") Arm
Max digging reach	A	9120 mm (29' 11")	9530 mm (31' 3")
Max digging reach on ground	A'	8940 mm (29' 4")	9360 mm (30' 9")
Max digging depth	B	5480 mm (18' 0")	5890 mm (19' 4")
Max digging depth (8ft level)	B'	5360 mm (17' 7")	5770 mm (18' 11")
Max vertical wall digging depth	C	4560 mm (15' 0")	4990 mm (16' 4")
Max digging height	D	10300 mm (33' 10")	10670 mm (35' 0")
Max dumping height	E	7390 mm (24' 3")	7740 mm (25' 5")
Min swing radius	F	2870 mm (9' 5")	2670 mm (8' 9")
Bucket digging force	SAE	133 [146] kN	133 [146] kN
		13600 [14840] kgf	13600 [14840] kgf
		29980 [32710] lbf	29980 [32710] lbf
	ISO	152 [166] kN	152 [166] kN
		15500 [16910] kgf	15500 [16910] kgf
		34170 [37280] lbf	34170 [37280] lbf
Arm digging force	SAE	135 [148] kN	113 [123] kN
		13800 [15050] kgf	11500 [12550] kgf
		30420 [33190] lbf	25350 [27650] lbf
	ISO	142 [155] kN	118 [128] kN
		14500 [15820] kgf	12000 [13090] kgf
		31970 [34880] lbf	26460 [28870] lbf

* : Standard [] : Power boost

4. WEIGHT

1) R210NLC-9

Item	R210NLC-9	
	kg	lb
Upperstructure assembly	8950	19730
Main frame weld assembly	1740	3840
Engine assembly	560	1240
Main pump assembly	170	370
Main control valve assembly	220	490
Swing motor assembly	240	530
Hydraulic oil tank weld assembly	165	360
Fuel tank assembly	123	270
Counterweight	4700	10360
Cab assembly	500	1100
Lower chassis assembly	8400	18520
Track frame weld assembly	2525	5570
Swing bearing	290	640
Travel motor assembly	300	660
Turning joint	55	120
Track recoil spring and idler	140	310
Idler	170	370
Carrier roller	20	45
Track roller	40	90
Track-chain assembly (500 mm standard triple grouser shoe)	1200	2650
Front attachment assembly (5.65 m boom, 2.92 m arm, 0.87 m ³ SAE heaped bucket)	3970	8750
5.65 m boom assembly	1360	3000
2.92 m arm assembly	750	1650
0.87 m ³ SAE heaped bucket	740	1630
Boom cylinder assembly	180	400
Arm cylinder assembly	290	640
Bucket cylinder assembly	175	390
Bucket control link assembly	170	370













5. LIFTING CAPACITIES

1) ROBEX 210NLC-9

(1) 5.65 m (18' 6") boom, 2.92 m (9' 7") arm equipped with 0.87 m³ (SAE heaped) bucket, 500 mm (20") triple grouser shoe and 4700 kg (10360 lb) counterweight.











•  : Rating over-front

•  : Rating over-side or 360 degree













Load point height		Load radius										At max. reach		
		1.5 m (5.0 ft)		3.0 m (10.0 ft)		4.5 m (15.0 ft)		6.0m (20.0 ft)		7.5 m (25.0 ft)		Capacity		Reach
														m (ft)
7.5 m (25.0 ft)	kg lb											*3390 *7470	2880 6350	7.76 (25.5)
6.0 m (20.0 ft)	kg lb								*2190 *4830	*2190 *4830	*3490 *7690	2250 4960	8.73 (28.6)	
4.5 m (15.0 ft)	kg lb						*4020 *8860	*4020 *8860	*3860 *8510	2890 6370	*3620 *7980	1920 4230	9.30 (30.5)	
3.0 m (10.0 ft)	kg lb			*9680 *21340	*9680 *21340	*6130 *13510	*6130 *13510	*4850 *10690	4040 8910	*4250 *9370	2760 6080	3700 8160	1750 3860	9.58 (31.4)
1.5 m (5.0 ft)	kg lb			*9170 *20220	*9170 *20220	*7960 *17550	5770 12720	*5780 *12740	3750 8270	*4740 *10450	2610 5750	3650 8050	1710 3770	9.57 (31.4)
Ground Line	kg lb			*9770 *21540	*9770 *21540	*9200 *20280	5400 11900	*6530 *14400	3530 7780	*5160 *11380	2490 5490	3800 8380	1770 3900	9.29 (30.5)
-1.5 m (-5.0 ft)	kg lb	*8900 *19620	*8900 *19620	*12810 *28240	10070 22200	*9670 *21320	5260 11600	*6920 *15260	3420 7540	5200 11460	2430 5360	4210 9280	1990 4390	8.71 (28.6)
-3.0 m (-10 ft)	kg lb	*12300 *27120	*12300 *27120	*14140 *31170	10210 22510	*9410 *20750	5280 11640	*6810 *15010	3420 7540			*4530 *9990	2470 5450	7.73 (25.4)
-4.5 m (-15.0 ft)	kg lb			*12030 *26520	10530 23210	*8220 *18120	5450 12020					*4400 *9700	3720 8200	6.14 (20.1)

- Note
1. Lifting capacity are based on SAE J1097 and ISO 10567.
 2. Lifting capacity of the ROBEX series does not exceed 75% of tipping load with the machine on firm, level ground or 87% of full hydraulic capacity.
 3. The load point is a hook located on the back of the bucket.
 4. *indicates load limited by hydraulic capacity.

(2) 5.65 m (18' 6") boom, 2.00 m (6' 7") arm equipped with 0.87 m³ (SAE heaped) bucket, 500 mm (20") triple grouser shoe and 4700 kg (10360 lb) counterweight.

Load point height		Load radius								At max. reach		
		3.0 m (10.0 ft)		4.5 m (15.0 ft)		6.0m (20.0 ft)		7.5 m (25.0 ft)		Capacity		Reach
												m (ft)
7.5 m (25.0 ft)	kg									*4040	3790	6.61
	lb									*8910	8360	(21.7)
6.0 m (20.0 ft)	kg					*4460	4350			*4100	2790	7.75
	lb					*9830	9590			*9040	6150	(25.4)
4.5 m (15.0 ft)	kg			*5710	*5710	*4870	4200	*4870	2730	*4230	2330	8.41
	lb			*12590	*12590	*10740	9260	*10740	6020	*9330	5140	(27.6)
3.0 m (10.0 ft)	kg			*7460	6110	*5630	3950	*5220	2620	4340	2110	8.71
	lb			*16450	13470	*12410	8710	*11510	5780	9570	4650	(28.6)
1.5 m (5.0 ft)	kg			*9010	5630	*6420	3720	5320	2550	4290	2070	8.71
	lb			*19860	12410	*14150	8200	11730	5620	9460	4560	(28.6)
Ground Line	kg			*9750	5410	*6960	3560			4520	2180	8.40
	lb			*21500	11930	*15340	7850			9960	4810	(27.6)
-1.5 m (-5.0 ft)	kg	*14190	10420	*9720	5390	*7060	3520			*4960	2520	7.73
	lb	*31280	22970	*21430	11880	*15560	7760			*10930	5560	(25.4)
-3.0 m (-10 ft)	kg	*12700	10630	*8930	5500	*6420	3600			*4940	3340	6.58
	lb	*28000	23440	*19690	12130	*14150	7940			*10890	7360	(21.6)

(3) 5.65 m (18' 6") boom, 2.40 m (7' 10") arm equipped with 0.87 m³ (SAE heaped) bucket, 500 mm (20") triple grouser shoe and 4700 kg (10360 lb) counterweight.

Load point height		Load radius								At max. reach				
		1.5 m (5.0 ft)		3.0 m (10.0 ft)		4.5 m (15.0 ft)		6.0m (20.0 ft)		7.5 m (25.0 ft)		Capacity		Reach
														m (ft)
7.5 m (25.0 ft)	kg											*3730	3340	7.12
	lb											*8220	7360	(23.4)
6.0 m (20.0 ft)	kg							*4030	*4030			*3810	2530	8.18
	lb							*8880	*8880			*8400	5580	(26.8)
4.5 m (15.0 ft)	kg							*4500	4240	*4090	2840	*3950	2130	8.80
	lb							*9920	9350	*9020	6260	*8710	4700	(28.9)
3.0 m (10.0 ft)	kg					*6880	6210	*5300	3980	*4590	2740	4040	1950	9.09
	lb					*15170	13690	*11680	8770	*10120	6040	8910	4300	(29.8)
1.5 m (5.0 ft)	kg					*8570	5680	*6150	3720	5010	2610	3990	1900	9.08
	lb					*18890	12520	*13560	8200	11050	5750	8800	4190	(29.8)
Ground Line	kg			*9040	*9040	*9540	5400	*6780	3540	5290	2520	4180	1990	8.79
	lb			*19930	*19930	*21030	11900	*14950	7800	11660	5560	9220	4390	(28.8)
-1.5 m (-5.0 ft)	kg	*9890	*9890	*13740	10240	*9740	5320	*7020	3470			*4700	2270	8.16
	lb	*21800	*21800	*30290	22580	*21470	11730	*15480	7650			*10360	5000	(26.8)
-3.0 m (-10 ft)	kg	*14280	*14280	*13420	10430	*9190	5390	*6660	3510			*4780	2910	7.09
	lb	*31480	*31480	*29590	22990	*20260	11880	*14680	7740			*10540	6420	(23.3)
-4.5 m (-15.0 ft)	kg			*10800	*10800	*7490	5630							
	lb			*23810	*23810	*16510	12410							

6. BUCKET SELECTION GUIDE

1) GENERAL BUCKET

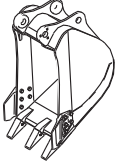
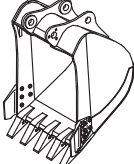
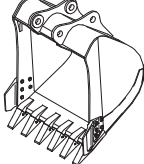
		
0.51 m ³ SAE heaped bucket	※ 0.87, 0.80, 0.92, 1.10, 1.20 m ³ SAE heaped bucket	1.34 m ³ SAE heaped bucket

Capacity		Width		Weight	Recommendation		
					5.65 m (18' 6") Mono boom		
SAE heaped	CECE heaped	Without side cutter	With side cutter		2.0 m arm (6' 7")	2.4 m arm (7' 10")	2.92 m arm (9' 7")
0.51 m ³ (0.67 yd ³)	0.45 m ³ (0.59 yd ³)	700 mm (27.6")	820 mm (32.3")	570 kg (1260 lb)			
0.80 m ³ (1.05 yd ³)	0.70 m ³ (0.92 yd ³)	1000 mm (39.4")	1120 mm (44.1")	700 kg (1540 lb)			
※ 0.87 m ³ (1.14 yd ³)	0.75 m ³ (0.98 yd ³)	1090 mm (42.9")	1210 mm (47.6")	740 kg (1630 lb)			
0.92 m ³ (1.20 yd ³)	0.80 m ³ (1.05 yd ³)	1150 mm (45.3")	1270 mm (50.0")	770 kg (1700 lb)			
1.10 m ³ (1.44 yd ³)	0.96 m ³ (1.26 yd ³)	1320 mm (52.0")	1440 mm (56.7")	830 kg (1830 lb)			
1.20 m ³ (1.57 yd ³)	1.00 m ³ (1.31 yd ³)	1400 mm (55.1")	1520 mm (60.0")	850 kg (1870 lb)			
1.34 m ³ (1.75 yd ³)	1.15 m ³ (1.50 yd ³)	1550 mm (61.0")	1670 mm (65.7")	920 kg (2030 lb)			

※ : Standard bucket

 Applicable for materials with density of 2000 kg/m³ (3370 lb/yd³) or less

 Applicable for materials with density of 1600 kg/m³ (2700 lb/yd³) or less

 Applicable for materials with density of 1100 kg/m³ (1850 lb/yd³) or less

2) HEAVY DUTY, ROCK-HEAVY DUTY AND SLOPE FINISHING BUCKET

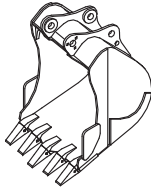
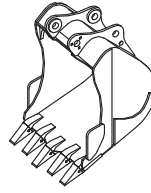
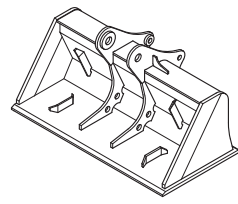
Heavy duty bucket	Rock-Heavy duty bucket	Slope finishing bucket
		
◆ 0.74, 0.90, 1.05 m ³ SAE heaped bucket	⊙ 0.87 m ³ SAE heaped bucket	■ 0.75 m ³ SAE heaped bucket

Capacity		Width		Weight	Recommendation		
					5.65 m (18' 6") boom		
SAE heaped	SAE heaped	Without side cutter	With side cutter		2.0 m arm (6' 7")	2.4 m arm (7' 10")	2.92 m arm (9' 7")
◆ 0.74 m ³ (0.97 yd ³)	0.65 m ³ (0.85 yd ³)	985 mm (38.8")	-	770 kg (1700 lb)			
◆ 0.90 m ³ (1.18 yd ³)	0.80 m ³ (1.05 yd ³)	1070 mm (42.1")	-	810 kg (1790 lb)			
◆ 1.05 m ³ (1.37 yd ³)	0.92 m ³ (1.20 yd ³)	1290 mm (50.8")	-	890 kg (1960 lb)			
⊙ 0.87 m ³ (1.14 yd ³)	0.75 m ³ (0.98 yd ³)	1140 mm (44.9")	-	900 kg (1980 lb)			
■ 0.75 m ³ (0.98 yd ³)	0.65 m ³ (0.85 yd ³)	1790 mm (70.5")	-	880 kg (1940 lb)			

◆ : Heavy duty bucket ⊙ : Rock-Heavy duty bucket ■ : Slope finishing bucket

 Applicable for materials with density of 2000 kg/m³ (3370 lb/yd³) or less

 Applicable for materials with density of 1600 kg/m³ (2700 lb/yd³) or less

 Applicable for materials with density of 1100 kg/m³ (1850 lb/yd³) or less

7. UNDERCARRIAGE

1) TRACKS

X-leg type center frame is integrally welded with reinforced box-section track frames. The design includes dry tracks, lubricated rollers, idlers, sprockets, hydraulic track adjusters with shock absorbing springs and assembled track-type tractor shoes with triple grousers.

2) TYPES OF SHOES

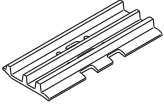
Model	Shapes		Triple grouser		
					
MONO BOOM	Shoe width	mm (in)	500 (20)	600 (24)	700 (28)
	Operating weight	kg (lb)	22000 (48500)	22300 (49200)	22600 (49820)
	Ground pressure	kgf/cm ² (psi)	0.56 (7.96)	0.47 (6.68)	0.41 (5.83)
	Overall width	mm (ft-in)	2500 (8' 2")	2600 (8' 6")	2700 (8'10")
ADJUST BOOM	Shoe width	mm (in)	500 (20)	600 (24)	-
	Operating weight	kg (lb)	21150 (46630)	21450 (47290)	-
	Ground pressure	kgf/cm ² (psi)	0.56 (7.96)	0.47 (6.68)	-
	Overall width	mm (ft-in)	2500 (8' 2")	2600 (8' 6")	-

3) NUMBER OF ROLLERS AND SHOES ON EACH SIDE

Item	Quantity
Carrier rollers	2 EA
Track rollers	9 EA
Track shoes	49 EA

4) SELECTION OF TRACK SHOE

Suitable track shoes should be selected according to operating conditions.

Method of selecting shoes

Confirm the category from the list of applications in **table 2**, then use **table 1** to select the shoe. Wide shoes (categories B and C) have limitations on applications. Before using wide shoes, check the precautions, then investigate and study the operating conditions to confirm if these shoes are suitable.

Select the narrowest shoe possible to meet the required flotation and ground pressure. Application of wider shoes than recommendations will cause unexpected problem such as bending of shoes, crack of link, breakage of pin, loosening of shoe bolts and the other various problems.

※ **Table 1**

Track shoe	Specification	Category
500 mm triple grouser	Standard	A
600 mm triple grouser	Option	B
700 mm triple grouser	Option	C

※ **Table 2**

Category	Applications	Applications
A	Rocky ground, river beds, normal soil	<ul style="list-style-type: none"> Travel at low speed on rough ground with large obstacles such as boulders or fallen trees
B	Normal soil, soft ground	<ul style="list-style-type: none"> These shoes cannot be used on rough ground with large obstacles such as boulders or fallen trees Travel at high speed only on flat ground Travel slowly at low speed if it is impossible to avoid going over obstacles
C	Extremely soft ground (swampy ground)	<ul style="list-style-type: none"> Use the shoes only in the conditions that the machine sinks and it is impossible to use the shoes of category A or B These shoes cannot be used on rough ground with large obstacles such as boulders or fallen trees Travel at high speed only on flat ground Travel slowly at low speed if it is impossible to avoid going over obstacles

8. SPECIFICATIONS FOR MAJOR COMPONENTS

1) ENGINE

Item	Specification
Model	Cummins QSB6.7 / HYUNDAI HE 6.7
Type	4-cycle turbocharged diesel engine, low emission
Cooling method	Water cooling
Number of cylinders and arrangement	6 cylinders, in-line
Firing order	1-5-3-6-2-4
Combustion chamber type	Direct injection type
Cylinder bore × stroke	107 × 124 mm (4.2" × 4.9")
Piston displacement	6700 cc (409cu in)
Compression ratio	17.2 : 1
Rated gross horse power (SAE J1995)	151 Hp at 1900 rpm (113 kW at 1900 rpm)
Maximum torque at 1500 rpm	63.0 kgf · m (456 lbf · ft)
Engine oil quantity	24 l (6.3 U.S. gal)
Dry weight	556 kg (1226 lb)
High idling speed	1950 ± 50 rpm
Low idling speed	850 ± 100 rpm
Rated fuel consumption	163.2 g/Hp · hr at 1900 rpm
Starting motor	Nippon denso (24 V-4.5 kW)
Alternator	Delco Remy (24 V-70 A)
Battery	2 × 12 V × 100 Ah

2) MAIN PUMP

Item	Specification
Type	Variable displacement tandem axis piston pumps
Capacity	2 × 117cc/rev
Maximum pressure	350kgf/cm ² (4980psi) [380 kgf/cm ² (5400 psi)]
Rated oil flow	2 × 222 l /min (58.6U.S. gpm/ 48.8U.K. gpm)
Rated speed	1900 rpm

[] : Power boost

3) GEAR PUMP

Item	Specification
Type	Fixed displacement gear pump single stage
Capacity	15 cc/rev
Maximum pressure	40 kgf/cm ² (570 psi)
Rated oil flow	28.5 l/min (7.5 U.S. gpm/6.3 U.K. gpm)

4) MAIN CONTROL VALVE

Item	Specification
Type	9 spools two-block
Operating method	Hydraulic pilot system
Main relief valve pressure	350 kgf/cm ² (4980 psi) [380 kgf/cm ² (5400 psi)]
Overload relief valve pressure	400 kgf/cm ² (5690 psi)

[]: Power boost

5) SWING MOTOR

Item	Specification
Type	Two fixed displacement axial piston motor
Capacity	151 cc/rev
Relief pressure	265 kgf/cm ² (3770 psi)
Braking system	Automatic, spring applied hydraulic released
Braking torque	59 kgf · m (427 lbf · ft)
Brake release pressure	33~50 kgf/cm ² (470~711 psi)
Reduction gear type	2 - stage planetary

6) TRAVEL MOTOR

Item	Specification
Type	Variable displacement axial piston motor
Relief pressure	350 kgf/cm ² (4980 psi)
Reduction gear type	2-stage planetary
Braking system	Automatic, spring applied hydraulic released
Brake release pressure	11 kgf/cm ² (156 psi)
Braking torque	49.3 kgf · m (357 lbf · ft)

7) REMOTE CONTROL VALVE

Item		Specification
Type		Pressure reducing type
Operating pressure	Minimum	6.5 kgf/cm ² (92 psi)
	Maximum	25 kgf/cm ² (360 psi)
Single operation stroke	Lever(1, 3 port)	90 mm (3.5 in)
	Pedal(2, 4 port)	130 mm (4.4 in)

8) CYLINDER

Item		Specification	
Boom cylinder	Bore dia × Rod dia × Stroke	∅ 120 × ∅ 85 × 1290 mm	
	Cushion	Extend only	
Arm cylinder	Bore dia × Rod dia × Stroke	∅ 140 × ∅ 100 × 1510 mm	
	Cushion	Extend and retract	
Bucket cylinder	Bore dia × Rod dia × Stroke	∅ 120 × ∅ 85 × 1055 mm	
	Cushion	Extend only	
Adjust boom cylinder	1st	Bore dia × Rod dia × Stroke	∅ 120 × ∅ 85 × 1290 mm
		Cushion	Extend only
	2nd	Bore dia × Rod dia × Stroke	∅ 160 × ∅ 100 × 1060 mm
		Cushion	Extend only

※ Discoloration of cylinder rod can occur when the friction reduction additive of lubrication oil spreads on the rod surface.

※ Discoloration does not cause any harmful effect on the cylinder performance.

8) SHOE

Item		Width	Ground pressure	Link quantity	Overall width
MONO BOOM	Standard	500 mm (20")	0.56 kgf/cm ² (7.96 psi)	49	2500 mm (8' 2")
	Option	600 mm (24")	0.47 kgf/cm ² (6.68 psi)	49	2600 mm (8' 6")
		700 mm (28")	0.41 kgf/cm ² (5.83 psi)	49	2700 mm (8' 10")
ADJUST BOOM	Standard	500 mm (20")	0.56 kgf/cm ² (7.96 psi)	49	2500 mm (8' 2")
	Option	600 mm (24")	0.48 kgf/cm ² (6.83 psi)	49	2600 mm (8' 6")

10) BUCKET

Item	Capacity		Tooth quantity	Width	
	SAE heaped	CECE heaped		Without side cutter	With side cutter
Standard	0.87 m ³ (1.14 yd ³)	0.75 m ³ (0.98 yd ³)	5	1090 mm (42.9")	1120 mm (47.6")
Option	0.51 m ³ (0.67 yd ³)	0.45 m ³ (0.59 yd ³)	3	700 mm (27.6")	820 mm (32.3")
	0.80 m ³ (1.05 yd ³)	0.70 m ³ (0.92 yd ³)	5	1000 mm (39.4")	1120 mm (44.1")
	0.92 m ³ (1.20 yd ³)	0.80 m ³ (1.05 yd ³)	5	1150 mm (45.3")	1270 mm (50.0")
	1.10 m ³ (1.44 yd ³)	0.96 m ³ (1.26 yd ³)	5	1320 mm (52.0")	1440 mm (56.7")
	1.20 m ³ (1.57 yd ³)	1.00 m ³ (1.31 yd ³)	5	1400 mm (55.1")	1520 mm (60.0")
	1.34 m ³ (1.75 yd ³)	1.15 m ³ (1.50 yd ³)	6	1550 mm (61.0")	1670 mm (65.7")
	◆0.74 m ³ (0.97 yd ³)	0.65 m ³ (0.85 yd ³)	5	985 mm (38.8")	-
	◆0.90 m ³ (1.18 yd ³)	0.80 m ³ (1.05 yd ³)	5	1070 mm (42.1")	-
	◆1.05 m ³ (1.37 yd ³)	0.92 m ³ (1.20 yd ³)	5	1290 mm (50.8")	-
	◎0.87 m ³ (1.14 yd ³)	0.75 m ³ (0.98 yd ³)	5	1140 mm (44.9")	-
	■0.75 m ³ (0.98 yd ³)	0.65 m ³ (0.85 yd ³)	-	1790 mm (70.5")	-

◆ : Heavy duty bucket

◎ : Rock-heavy duty bucket

■ : Slope finishing bucket

9. RECOMMENDED OILS

Use only oils listed below. Do not mix different brand oil.

Please use HYUNDAI genuine oil and grease.

Service point	Kind of fluid	Capacity ℓ (U.S. gal)	Ambient temperature °C (°F)						
			-50 (-58)	-30 (-22)	-20 (-4)	-10 (14)	0 (32)	10 (50)	20 (68)
Engine oil pan	Engine oil	24 (6.3)	★SAE 5W-40						
			SAE 30						
			SAE 10W						
			SAE 10W-30						
			SAE 15W-40						
Swing drive	Gear oil	5.0 (1.3) ^{★2} 6.2 (1.7)	★SAE 75W-90						
Final drive		5.8 × 2 (1.5 × 2)	SAE 80W-90						
Hydraulic tank	Hydraulic oil	Tank; 165 (43.6) System; 290 (76.6)	★ISO VG 15						
			ISO VG 32						
			ISO VG 46						
			ISO VG 68						
Fuel tank	Diesel fuel	310 (81.9)	★ASTM D975 NO.1						
			ASTM D975 NO.2						
Fitting (grease nipple)	Grease	As required	★NLGI NO.1						
			NLGI NO.2						
Radiator (reservoir tank)	Mixture of antifreeze and soft water ^{★1}	35 (9.2)	Ethylene glycol base permanent type (50 : 50)						
			★ Ethylene glycol base permanent type (60 : 40)						

SAE : Society of Automotive Engineers
API : American Petroleum Institute
ISO : International Organization for Standardization
NLGI : National Lubricating Grease Institute
ASTM : American Society of Testing and Material

★² : Service when the grease
inlet exists on the equipment

★¹ : Soft water
City water or distilled water

★ : Cold region
Russia, CIS, Mongolia